



PROFESSIONAL INTERACTIVE LIDAR POELIDAR-M1



INTRODUCTION

POELIDAR-M1 is a cost-effective portable professional interactive radar developed by Shanghai CPJRobot Co., Ltd. for the interactive field.

Traditional Lidar is designed for the robot industry and some industrial applications. Its product form and parameter index are not suitable for the interactive field. For a long time, the use of the traditional radar in the interactive field is very awkward, there are a series of problems such as installation and debugging difficulties, low touch accuracy, short service life, index parameters can not be referred to, software docking chaos and so on. The emergence of POELIDAR professional interactive radar has solved a number of pain points in the industry at one stroke.

FEATURES



POE Technology One cable solution



Small, beautiful and portable



360° scan range



Stable multi-lidarcascade



Accurate parameter



easy to configure



PARAMETERS

RANGING PARAMETERS

Ranging principle	TOF (time of flying)
Radius	>4m(practical radius), Maximum distance 12m(70% reflectivity)
Touch Accuracy	Typical value <3cm (4m wall, when lidar is well mounted)
Detecting frame rate	10FPS
Scanning Angle	360°

MULTI-TOUCH PARAMETERS

Mouse Simulaiton	Simulate mouse click, drag and move
Multi-touch	Support TUIO protocol, windows multi-point protocol, mouse pseudo multi-point function
Point support	The TUIO protocol has no point capwindows windows Multi-point support up to a maximum of 256 points
Application interface	Support Unity, C#, C++, processing, and many other software
Interactive Area	Support rectangular area,square area ,circle area,trapezoid area, polygon area, etc.Support overlapping area scanned by muti-lidar Support flat, tri-folded surface, L-shaped and curved surface (use muti-lidar)
Display device	Support projectors, single projection or multiple integration are supported Support LED screen, any size screen, splicing screen, floor tile screen, pixel screen, etc
Multi-lidar casecade	One computer can support more than 20 lidars casecade at the same time

INTERFACE

Power supply interface	Ethernet, POE protocol power supply through ethernet cable
Data interface	Ethernet, POE protocol to transmit data through ethernet cable
Transmission distance	more than 100m
POE standard	IEEE 802.3AF
Network cablerequirements	CAT6 or batter cable
Playlists	Can call interactive game program loop play, different programs can set different protocols and play time
Start up	With the computer running touch control system, computer shutdown automatically shut down the radar

OTHERS

Weight	125.5g
Operating temperature	0~40°
Storage temperature	0~50°



DIMENSION

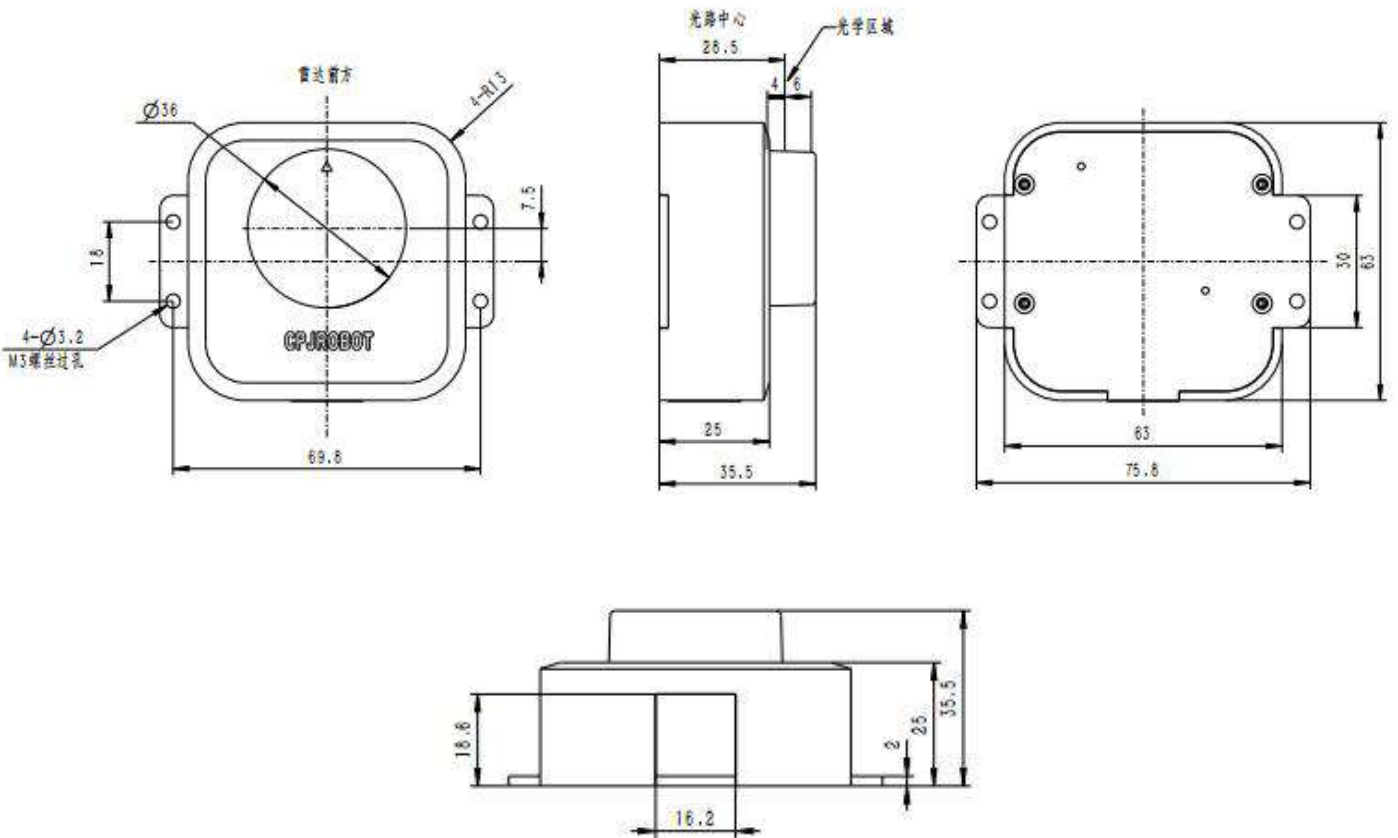
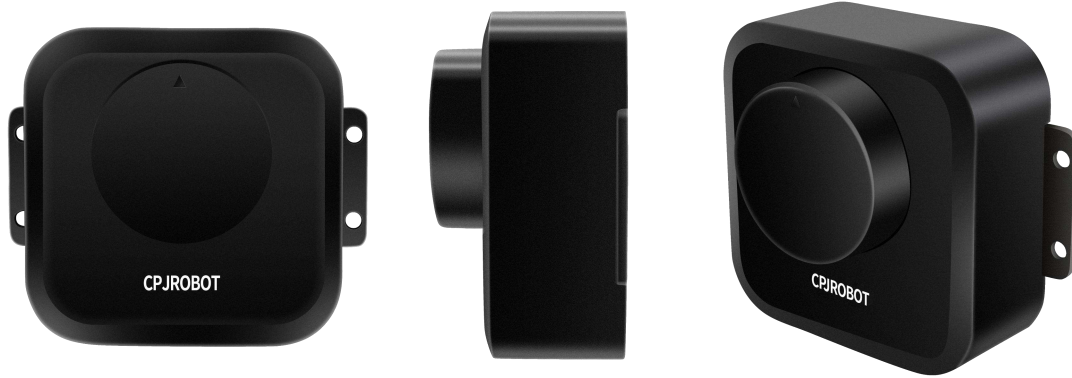

Units: mm

APPLICATIONS



Wall interaction



Floor interaction



Interactive arc curtain projection



Immersive space



Touch graphite wall

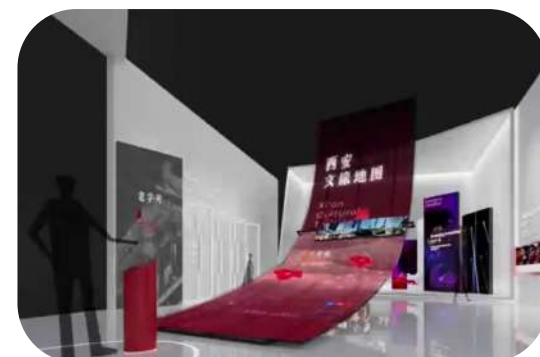

Shaped projection Interactive

CONTACT US

Email: info@cpjrobot.com

Telephone: +86 21 51769038

Mobile Phone: +86 17501616271
/+86 18616152997

Address: Building NO.1, 70th Lane, Haijiliu Road, Pudong District, Shanghai, China